

Ventilated and Insulated Rain Screen Cladding (V.I.R.S.C.)

1. GENERAL

This document presents some basic principles on a Ventilated and Insulated Rain Screen Cladding (VIRSC). However, one has to take into account that the hygrothermal behaviour of an external wall depends totally on its composition but also on the external climate. Conclusions valid in one climate are not always 100% transferable to another type of climate. Each time a thorough evaluation based on standard building physics needs to be made.

2. FAÇADE CLADDING MATERIAL

The following E.P.O. architectural panels can be used as outside wall cladding in a VIRSC system:

- | | |
|-------------------------------------|---------------|
| • GLASAL, ETERFLEX, GRANITEX | 7,5 mm |
| • CARAT, NATURA, PELICOLOR | 8 mm |
| • SIDINGS | 10 mm |

For product data and details of the processing of the various panels, reference is made to the product information sheets available from E.P.O.'s website.

3. COMPOSITION OF A VENTILATED AND INSULATED RAINSCREEN CLADDING

The basic section of an external wall construction composed in accordance to the VIRSC principle consists of:

- 1: a load bearing structure
- 2: a layer of thermal insulation on the outside of the load bearing structure
- 3: a ventilated air gap / cavity
- 4: an architectural panel

In addition, an intermediate supporting structure is used to connect the architectural panel to the load bearing structure.

The ventilation (circulation of air) is created in the cavity by leaving an open joint at the bottom and the top of the cladding. This principle must be followed consistently meaning e.g. that air in- and outlets should also be designed below and above windows.

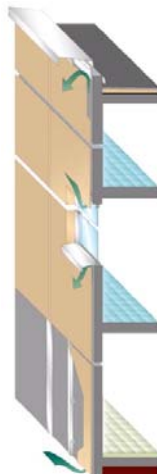

4. ADVANTAGES

A ventilated and insulated rainscreen cladding offers the following advantages:

- PREVENTION OF INTERNAL CONDENSATION

In cold seasons the partial vapour pressure inside the heated building is higher than outside, leading to a transport of vapour through the outside wall. This vapour could condensate in the air gap against the back of the architectural panel but the dry air that circulates through the cavity will eliminate this moisture.

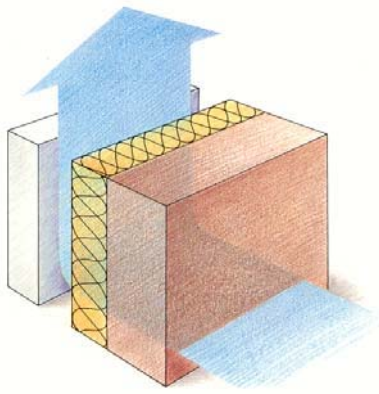

- COOLING EFFECT IN THE SUMMER

A very large portion of the solar radiation energy is dispersed before it even reaches the thermal insulation material:

- Depending on the colour used, some radiation will be reflected.
- The temperature of the panel itself increases, which consumes another part of the incoming energy.
- At last, the air in the air gap is heated up, creating a chimney effect that conveys continuously fresh outside air into the cavity, cooling down the whole construction.

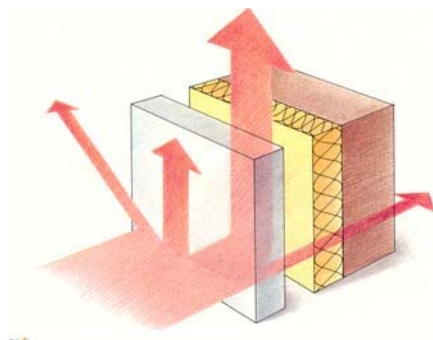

- **NO THERMAL BRIDGES**

Because the insulation is applied outside the supporting structure, this creates a continuous thermal barrier, so that thermal bridges and their associated problems – such as surface condensation and consecutive creation of unhealthy mould growth - are avoided.

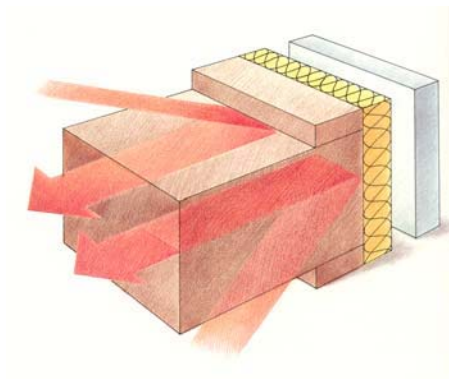

- **NO RAIN REACHES THE THERMAL INSULATION OR THE LOAD-BEARING CONSTRUCTION**

The outside wall cladding functions as an umbrella, so the internal construction remains dry. Moisture penetrating the cavity either runs down the back of the architectural panels or is removed by natural ventilation.

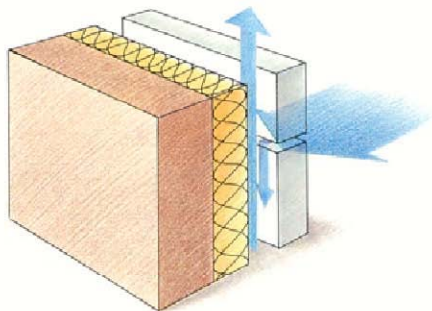

- **LOW TEMPERATURE VARIATION IN THE LOAD-BEARING CONSTRUCTION.**

Normally one tries to achieve a stable interior temperature but can not influence the exterior temperature variations. By installing the thermal insulation material on the outside of the load bearing construction, the biggest variation of temperature will occur inside the insulation material leaving only minor temperature variations in the interior wall. In this way the interior structure is protected from high thermal stresses and so the risk of cracks is reduced.

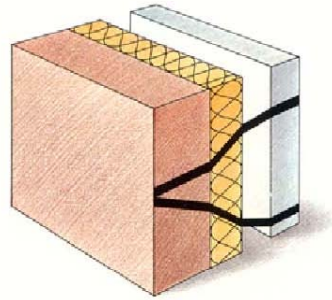

- **DIMENSIONAL STABILITY OF THE CLADDING MATERIAL**

Because the architectural panel is ventilated both at the front and at the back, there is almost no differential hygrothermal load working on it. This results in a stable panel behaviour.

5. SUPPORTING STRUCTURE

The supporting structure onto which the architectural panels are fixed can be made of:

- wood
- galvanised steel
- aluminium
- stainless steel

6. FIXING OF OUTSIDE WALL CLADDING

For the visible or secret fixing of the architectural panels to the supporting structure, please refer to the application instructions available from E.P.O.'s website.