



# Standard Installation Guidelines

ARCHITECTURAL PANELS



Metal Profiles with Rivets

+ RAINSCREEN APPLICATION  
8MM PANELS



These guidelines represent an abbreviated illustration for proper installation of AFC Stone and AFC Blast product lines in a ventilated rain screen application. Additional guidelines for interior applications, hidden adhesive attachment, sealing, and weather barrier attachment can be found at [americanfibercement.com](http://americanfibercement.com).

Note: The online copy of the Installation Guidelines obtained at [americanfibercement.com](http://americanfibercement.com) supersedes any printed copy.

## Construction Practices

1. Air space at top and bottom of building or wall termination to be 25 mm (1") to facilitate airflow from out behind the panels. Do not block vertical airflow at windows, doors, eaves, or at the base of the building. Airflow needs to be continuous from bottom to top so there is air movement behind each panel. See item 4 under Building/Structure on page 5 for proper profile depth based on wall height. 1" is required for walls between 15ft and 60ft. Vertical airflow behind the fiber cement panels is a critical necessity in rainscreen constructions.
2. For areas that receive moderate to high snowfall, panels must terminate 6 to 12 inches above grade line based on expected snow build-up.
3. A metal drip edge may be used at window heads, door heads, and the panel base, but it must not restrict airflow ( $\frac{3}{4}$ "; 1" at base openings).
4. Install panels from top of building to bottom.
5. For straight walls, start panel installation in center and work outward.
6. For walls with inside corners, start installation there and work across wall.
7. Jobsite storage:
  - Keep material laying flat, under cover, dry and protected with a waterproof tarp.
  - Transport material on edge.
  - Using a microfiber cloth, brush off any material dust generated by drilling or cutting prior to installation.
  - Do not use the shipping crates or pallets containing the fiber cement panels as a work surface. Keep panels dust-free.
8. For field cuts and drilling, use carbide or diamond blades/bits and slower turning/feed rates. AFC offers saw blades and drill bits.
9. Depending on the product type, Edge Sealer/Paint may or may not be required. See AFC's Fabrication, Maintenance, and Storage guidelines.

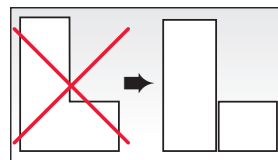

L or C-Shaped panels are not allowed.

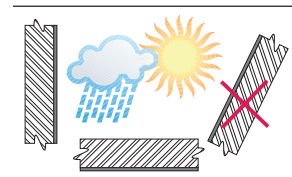

**Panels exposed to weather** (rain, sun) may only be assembled vertically. Soffit applications not exposed to weather are allowed.

# Construction Practices

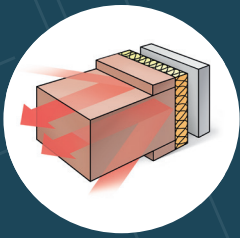

## Preventing Thermal Bridges

As the insulating material is on the outside of the structural wall, it can easily be mounted without interruptions caused by floor slabs. In this way, any thermal bridges that occur at each floor slab can be prevented. These thermal bridges are also the cause of surface condensation that may result in fungus growth.

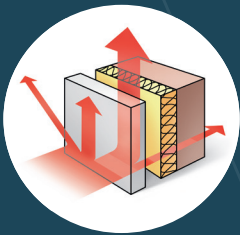

## Dissipating Heat From the Sun

The ventilated rainscreen cladding system has a cooling effect when temperatures outside are high. Most of the sun's rays are reflected away from the building. Heat passing through the exterior wall panel is partially dissipated by the ventilating effect of the air space between the exterior cladding panel and the structural wall. Any residual heat managing to penetrate buildings is very minor.

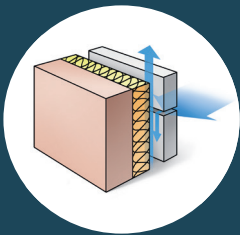

## Rainscreen

Architectural wall-cladding panels act as a rainscreen on the outside of the building and keep the structural wall absolutely dry. The air space connected to the outside air evacuates water and humidity that might have penetrated behind the wall-cladding panels through its horizontal or vertical joints. This water will never reach the load-bearing wall and/or the thermal insulation.

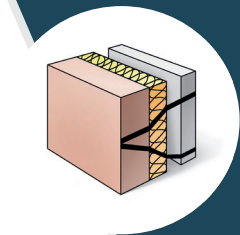

## Protecting the Basic Structure and Load-Bearing Wall Against Temperature Variations

In view of the fact that the insulation material is applied to the outside of the building, changes in temperature are very minor compared with those found in conventional constructions where insulation is applied on the interior. This principle works in summer and winter, in both hot and cold climates.

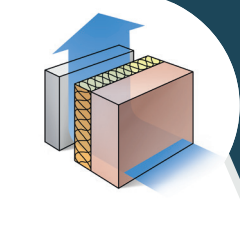

## Prevention of Internal Condensation

Insulation material can be applied to the outside of the structural wall because it is protected effectively by the architectural exterior wall panel. Because of differences in vapor pressure and temperature passing through the wall, condensation has been shown to occur close to the ventilated area and not in the structural wall itself. As a result, the ventilating effect is easily sufficient to dry out the thermal insulating material.

*Panels exposed to weather (rain, sun) may only be assembled vertically. Soffit applications not exposed to weather are allowed.*

1. **Architect / Engineer / Contractor to design and build structurally sound, water-tight exterior wall.**

- Substructure Horizontal Straightness Tolerance:  $\pm 3.0$  mm per 2m ( $\pm 0.0625$ " per 42")
- Substructure Vertical Straightness Tolerance:  $\pm 0.5$  mm per 600mm ( $\pm 0.0625$ " per 75")

If the wall is not straight, the profiles should be shimmed to create a flat plane for the panels. Shims should not be used between the profile and the panel.

2. Attach profiles to exterior walls. Structural engineer to determine fastening/affixing specification, i.e. quantity and type of attachment and fasteners, based upon exterior wall construction. Attachment must support 3.2 lbs/ft<sup>2</sup> (8mm panel) dead load, plus design wind loads. Fasteners in profile must accommodate thermal expansion/ contraction of metal and not interfere with panel application. Shortening the length of the profiles can minimize thermal expansion and contraction. It is also recommended to oversize holes at or near the tops and bottoms of the profiles while having fixed points near the center. This reduces stress in the panels.

FIG. A

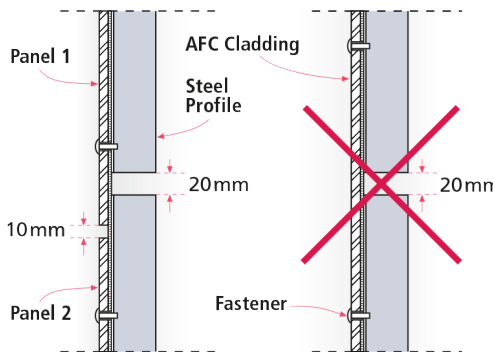

FIG. B

**Standard profile.** Affix adhesive foam tape to either or both sides of rivet. (Foam tape will compress to correct depth when panel is fastened.)

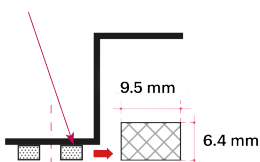

FIG. C

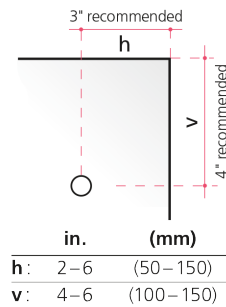
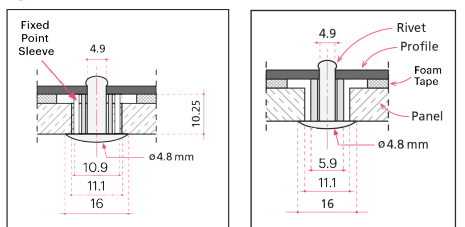

FIG. E



**Fixed Point** — cylinder & rivet      **Gliding Point** — cylinder & rivet

3. Profiles for affixing panels to be a minimum of 16 gauge steel or 2 mm aluminum, determined by building orientation/ location and load factors. For steel, depending on location and climate, a minimum of G90 or greater hot-dipped galvanized coating is required. Galvalume® and powder coat finishes may also be used. The surface of the profile the panel is attached to must be completely flat. (See FIG. J-2)
4. Vertical profiles for affixing panels must be the following depth to allow for optimal airflow and water drainage:
- 19 mm (¾") for panel runs 0-15 ft
  - 25 mm (1") for panel runs 15-60 ft
  - 32 mm (1¼") for panel runs 60-100 ft
  - 38 mm (1½") for panel runs 100-150 ft
- For buildings over 150 feet high, special provisions are required; check with your AFCladding representative.
5. Maximum length of metal profile  $\leq 10$  feet. Two profiles ("Z" recommended, or "Hat" with  $\geq 1\frac{1}{4}$ " legs— legs) are recommended in place of one wide profile at vertical joints. The sides of the panel can be cantilevered 2"- 6" over edge profile so vertical joint is open. (See FIG. C)
6. Profiles to be straight, plumb, level, and aligned correctly on the building. For installations without exterior insulation, the metal profiles are typically hat-channels or Z-channels affixed directly to the exterior wall, provided the sheathing has adequate screw-holding strength. (See FIG. J)
7. It is recommended to take field measurements before panels are cut or drilled. Field measurements verify print dimensions to ensure proper fit.
8. Spacing between vertical profiles to be  $\geq 20$  mm (¾"). A joint between the vertical profiles must always coincide with a joint between the panels (See FIG. A). The joint is preferably continued at the same horizontal height among adjacent profiles. (Reduces stress in panels). If a two-layer system is used, the same concept must be applied for the horizontal profiles. 20mm spacing, and coincide a joint between panels with a joint between horizontal profiles.
9. For structures with exterior insulation, follow the insulation manufacturer's installation instructions. Horizontal metal profiles (the same depth as the exterior insulation) can be attached to the exterior wall. Vertical metal profiles are then attached to the horizontal profiles (See FIG. D-A).

## Prepare Profile

1. Typical vertical and horizontal joints are left open and have a black background (use a black weather and UV-resistant building wrap). Metal profiles visible at joint openings (vertical and horizontal) can be covered with a black UV weather-resistant tape or UV weather-resistant coating. Other reveal colors are possible if desired.
2. Affix adhesive foam tape (supplied by AFC) to the profile's full length — 1 strip on either side of the rivet location or 1 strip on each side of the rivet location, no more than ½" from the rivet location. At vertical joints, place 1 strip on the panels' center side of the rivet location. (See FIG. B)
3. See page 7 regarding closing horizontal and vertical joints.

# Profile Attachment – ILLUSTRATED

For wall assemblies utilizing exterior sheathing with low screw-holding strength, a two-layer attachment system may be required. (See fig. D-1B)

Contact your AFC representative or visit AFC's website for application instructions utilizing Dynamic Bond adhesive

**FIG. D-1A-**

Vertical profiles are typically "Z" channels or "Hat" channels.

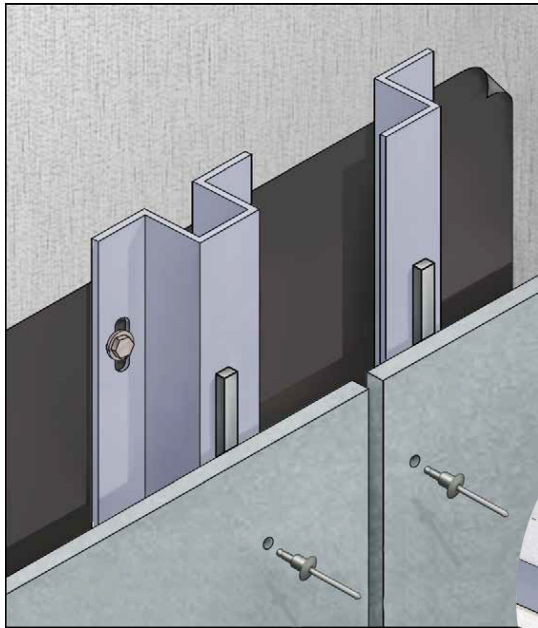

Hat channel can be attached with the crown facing in or out, depending on fastener spacing and the visibility of the profile through the joint.

**FIG. D-1B-**

Building wrap per AFC. Weather and UV resistant. Check local codes for proper placement.

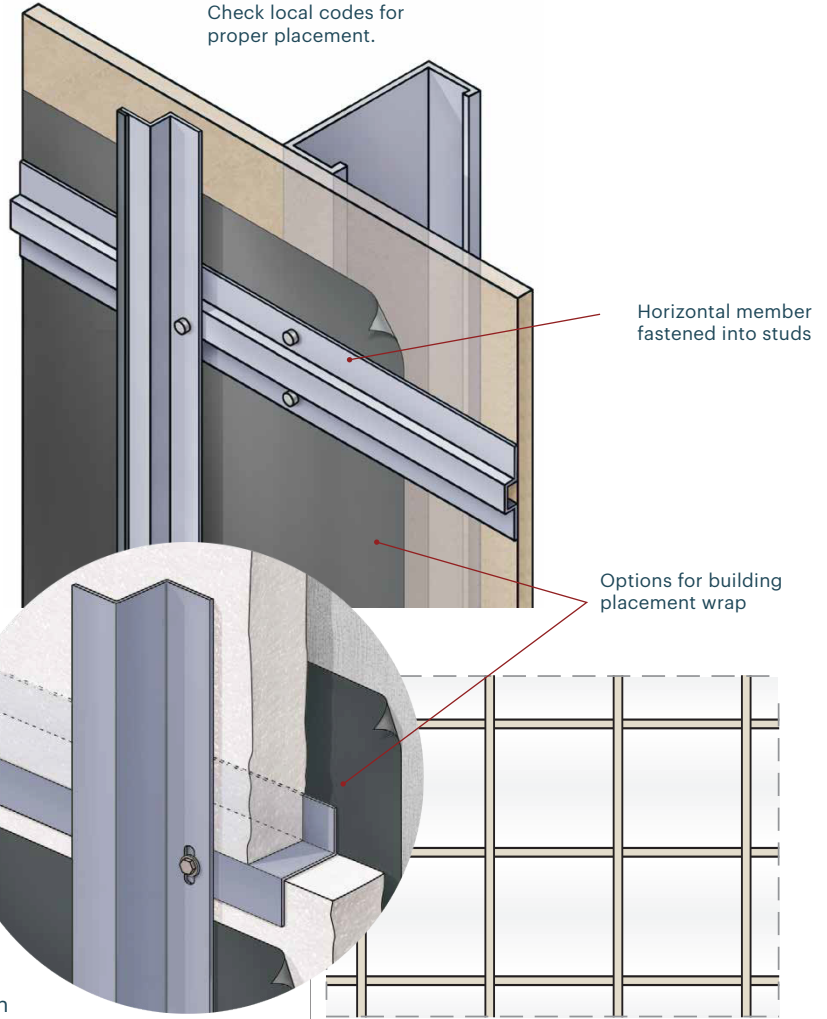

**FIG. J-2**

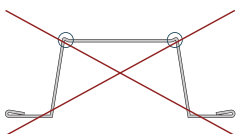
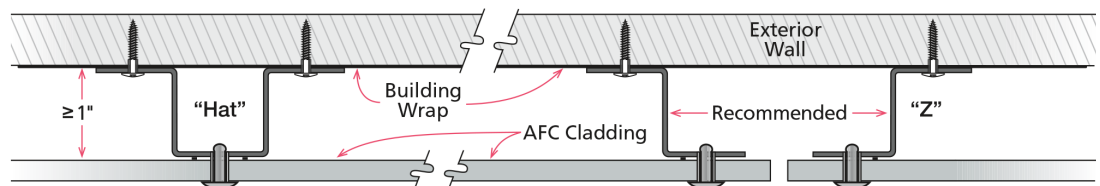

**FIG. D-2-**

Exterior insulation, when vertical profiles are attached to horizontal profiles affixed to wall.

**FIG. J-1**

"Hat" or "Z" channels and vertical joint. (G90/Powder Coated Steel and Mill/Anodized Black Aluminum "Z" channels offered by AFC.)



Can be vertically affixed directly to wall if there is no exterior insulation, provided sheathing has adequate screw-holding strength; (3/4" plywood sheathing is recommended).

**FIG. H** Astro Rivet® with fixed cylinder

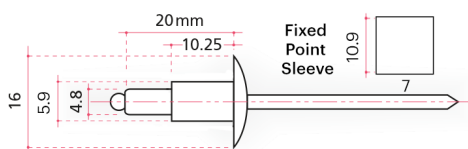

**FIG. I** Centralizing drill bit

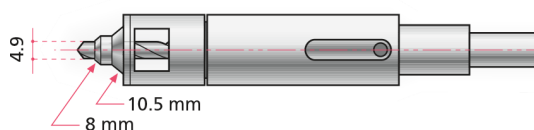

For centering pilot hole in profile for Fixed Points and Gliding Points.

# Panels

1. Some AFC Fiber Cement Products have a sanding grain that must be accounted for when positioning panels. Rotating some panels 90° from the orientation of adjacent panels can result in the appearance of color shading.
2. Vertical and horizontal joints to be 10mm (3/8"). This is the minimum distance between the edges of two adjacent panels, or the distance from panel edge to metal trim extrusions or structural members. (See FIG. A)
3. Pre-drill holes in panel. Diameter of the fixed and gliding point holes are all 11.1mm (7/16"). Drill bits supplied by AFC.
4. Joints between profiles must coincide with horizontal joints in the panels. Panels cannot bridge a break in the profiles. (See FIG. A)

## VENTILATED RAINSCREEN APPLICATION

5. The pilot hole in metal profile must be in the center of both the fixed point and gliding point holes. Use a drill bit centralizing fixture (supplied by AFC) to accomplish this geometry. Pilot hole to be 4.9 mm in diameter — use #10 drill bit (4.9 mm). (See FIG. I)
6. Affix the two fixed-point holes first. For the fixed-point holes, the AFC supplied 10.9mm diameter sleeves must be slid onto the rivet before affixing. (See FIG. H)

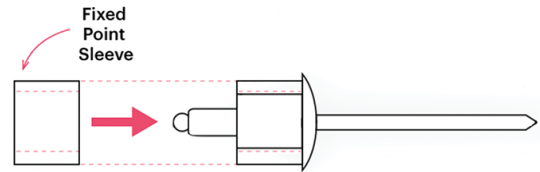

# Fixing

1. Rivets to be Astro Rivet (supplied by AFC) with colored or stainless steel head with 5.9 mm x 11.5 mm cylinder. Shank of rivet is 4.8 mm x 20 mm long, with a 16 mm diameter head. (See FIG. H)
2. Fixing pattern is typically either 16" or 24" (max) on center horizontally (based upon vertical profile spacing) and 16" to 24" (max) on center vertically, depending upon building height, building location, design criteria/specifications, and panel/fastener location on building. Edge areas on facades and high wind load conditions require closer fixing distances. Structural engineer to determine spacings. For soffit applications, the maximum fastener spacing is 16" on center in both directions.
3. Corner rivets to be located at 50 – 150 mm (2"– 6") horizontally and 100 – 150 mm (4"– 6") vertically from every corner of panel. (See FIG. C)
4. 10 mm (3/8") clearance is required from the edge of metal profile to pilot hole for rivet.
5. Two fixed points are required per panel. (figs. I & J) Fixed points (for attachment to vertical profiles) are:
  - Always the same height in each panel.
  - As close to center of panel as possible, and then either the next adjacent point to the left or right. Be consistent in panel-to-panel location (center and left or center and right, so fixed points are at the same level horizontally for attachment to vertical profiles).
  - No two fixed points on one panel can be on the same profile, and no two fixed points on two adjacent panels can be on the same profile when adjacent panels share a profile at a vertical joint.
  - For smaller panel sizes with only two rows of fasteners, fixed points to be top center and top left or top right (horizontal applications on vertical profiles). For vertical narrow panel applications on vertical profiles, vertical joints must incorporate two separate profiles (as illustrated, fig J).

**FIG. F -**  
Vertical installation  
on vertical profiles

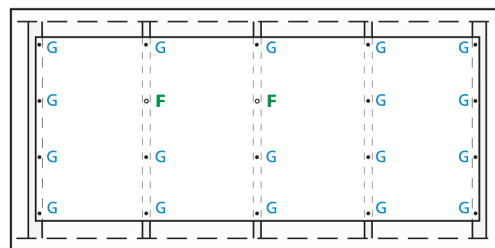
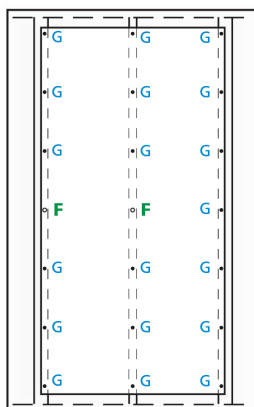

If there is no perfectly centered row, the fixed points go one row up, as shown.

**FIG. G -**  
Horizontal  
installation  
on vertical  
profiles

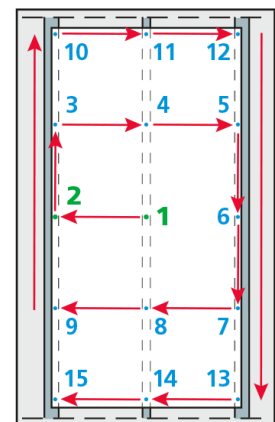

**FIG. K -**  
Fixing sequence  
Attach fixed points first.

## Fixing (Continued)

6. Joint closures can be installed (maximum thickness of finishing profile to be .8 mm or 21 gauge). Standard practice is to leave the joints open. If the joints are closed, the base and parapet openings must be increased to a minimum of 1½".
7. Pilot hole for rivet in metal profile to be 4.9 mm diameter. See Panel section for drill size. (See **FIGS. E AND I**)
8. Remove drill shavings from metal profile holes and panel fixed and gliding holes prior to installing rivets.

## Fabrication/Maintenance/Storage

Panels can be used full size (4' x 8' or 4' x 10'), or fabricated to smaller dimensions.

## Typical Pattern Layout

Panels can be used full size (4' x 8' or 4' x 10'), or fabricated to smaller dimensions.

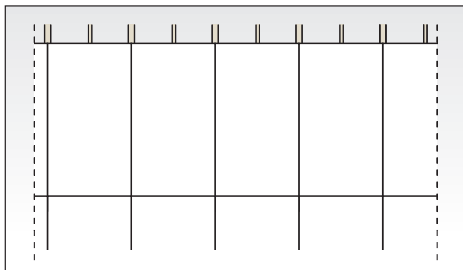

Straight pattern with vertical panels

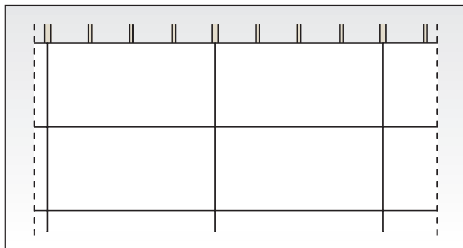

Straight pattern with horizontal panels

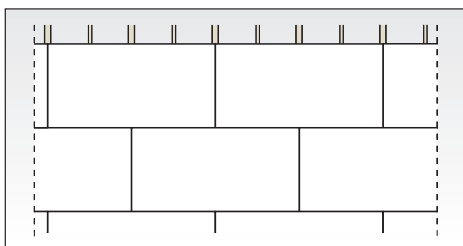

Semi pattern with horizontal panels



### Typical Horizontal Panel Joint

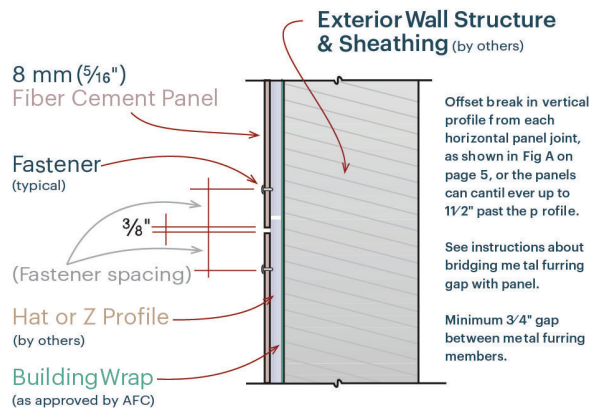

### Typical Vertical Panel Joint

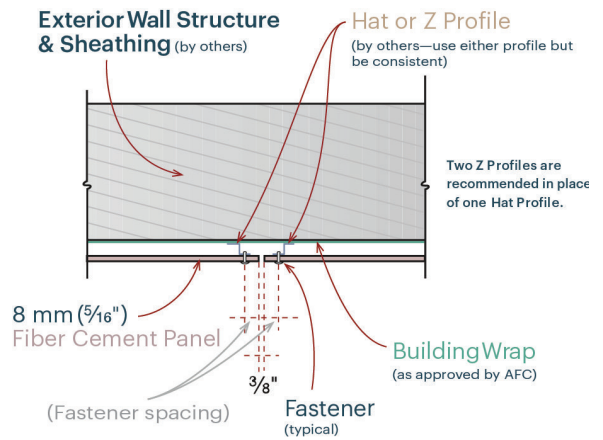

### Typical Panel Base

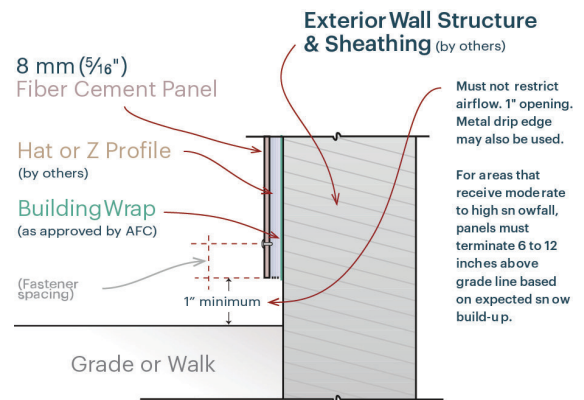



### Typical Inside Corner – Plan View

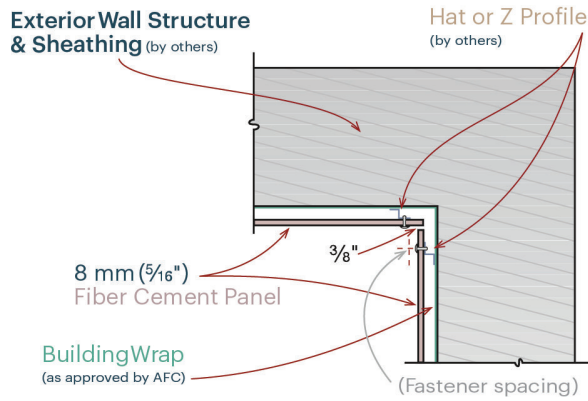

### Typical Panel @ Window Head or Door Head

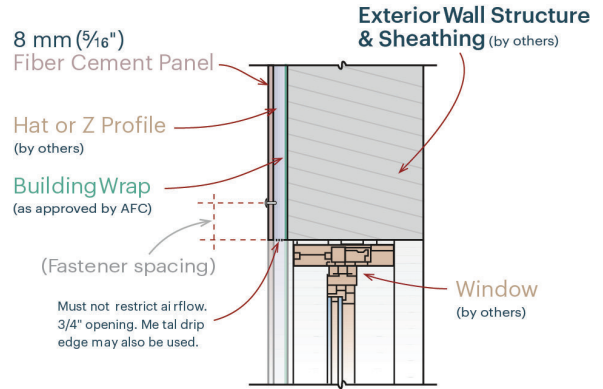

### Typical Outside Corner – Plan View

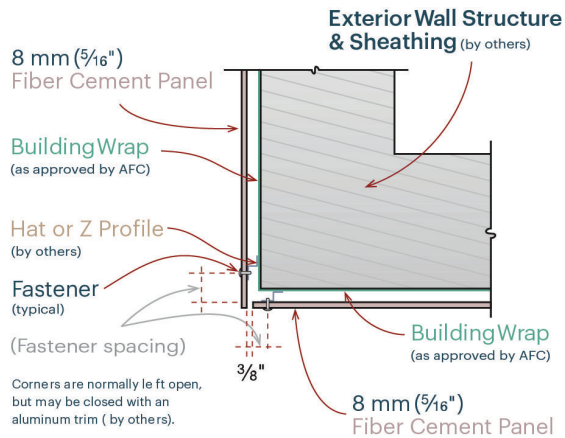

### Parapet Coping – Closeup

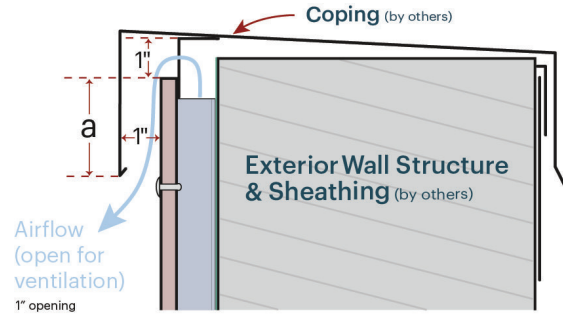

Building Height (ft)	Dimension (a)
0-30	1"
30-50	2"
50-80	3"
80+	4"

### Typical Panel End @ Metal Panel

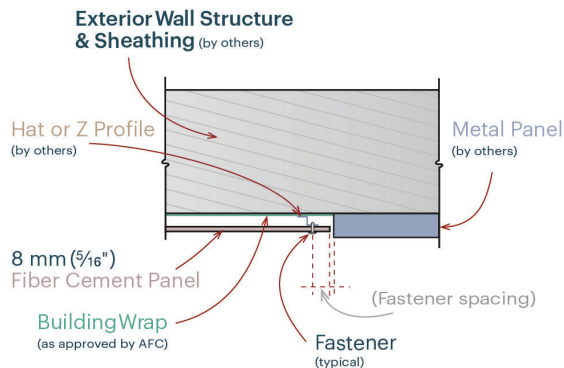

### Typical Panel @ Parapet

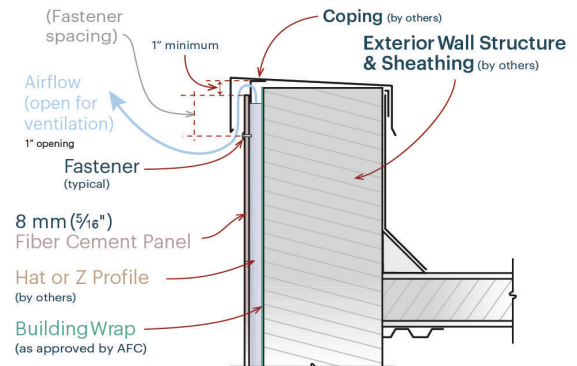

# Product Sustainability Statement

AFC is committed to providing the highest quality high-density compressed fiber cement panels to the U.S. building markets. In order to do this, we feel it necessary to provide not only high-quality products, but sustainable products that can contribute to green (LEED) building projects, which in turn benefit the environment we all live in. AFC products currently have a potential contribution to various LEED credits including but not limited to:

## Direct Contribution

Materials and Resources:

- Environmental Product Declarations
- Material Ingredients
- Building Life-cycle Impact Reduction

## Indirect Contribution

Indoor Environmental Quality:

- Thermal Comfort

## Energy and Atmosphere:

- Optimize Energy Performance

One of the most important sustainable attributes is the durability of AFC panels. With their long lifespan, virtually requiring no refurbishment, AFC panels can contribute to less replacement of materials and to drastically lower maintenance costs over the useful life of the building.

The Ventilated and Insulated Rainscreen Cladding (VIRSC) system, which is used to affix AFC panels to the exterior of a structure, offers many benefits and green attributes to the performance of the building envelope. Durability and resistance to moisture and mold build-up are noteworthy benefits. Equally important is its ability to accommodate external insulation.

In addition, AFC is dedicated to further research and analysis of our products to achieve additional LEED credits, and help further the cause of building sustainable and efficient buildings.

Warranty information available upon request.

---

6901 South Pierce Street  
Suite 180, Littleton, CO 80128 U.S.A.  
Phone: 303.972.5107, 800.688.8677

[americanfibercement.com](http://americanfibercement.com)

For the nearest authorized fabricator, call 303.972.5107.

Distributed exclusively by:



# Limited Warranty

American Fiber Cement Corporation (AFC) warrants that its products are manufactured in accordance with its applicable material specifications and are free from defects in materials and workmanship using AFC's specifications as a standard. Only products which are installed and used in accordance with applicable AFC instructions and specifications are in any way warranted by AFC. This warranty is applicable only to claims made in writing and received by AFC within thirty (30) days after the defect was discovered and within ten (10) years after the date of the shipment of the product by AFC. All other claims are waived. If a claim is made, you must allow reasonable investigation of the product you claim is defective and you must supply samples that adequately demonstrate the problem you claim for testing by AFC.

AFC DISCLAIMS ALL IMPLIED WARRANTIES INCLUDING THE WARRANTY OF MERCHANTABILITY AND THE WARRANTY OF FITNESS FOR A PARTICULAR PURPOSE THIS LIMITED WARRANTY PROVIDES YOUR EXCLUSIVE REMEDY AS A PURCHASER OF AFC PRODUCTS. THIS LIMITED WARRANTY MAY BE MODIFIED OR AMENDED ONLY BY A WRITTEN INSTRUMENT SIGNED BY A DULY AUTHORIZED REPRESENTATIVE OF AFC. WITHOUT AN EXPRESS, WRITTEN AUTHORIZATION FROM AFC, NO RETAILER OR DISTRIBUTOR OF AFC PRODUCTS HAS THE AUTHORITY TO MODIFY OR AMEND THIS LIMITED WARRANTY.

# Limitation of Liability

This limited warranty is your sole and exclusive remedy. It is expressly understood and agreed that the limit of liability will be, at AFC's option, repair, resupply of a like quantity of non-defective product, or refund of purchase price of the material. All labor and service charges which may be incurred with respect to either the original or replacement product are excluded. AFC shall have no liability except where the claim results solely from breach of AFC's limited warranty.

AFC SHALL NOT BE LIABLE FOR ANY INCIDENTAL OR CONSEQUENTIAL DAMAGES. FURTHERMORE, AFC SHALL NOT BE LIABLE FOR DAMAGE TO THE PROPERTY TO WHICH THE PRODUCT IS APPLIED OR ITS CONTENTS, LOSS OF TIME, PROFITS, OR ANY INCONVENIENCE ARISING OUT OF ANY BREACH OF THIS LIMITED WARRANTY OR OBLIGATIONS UNDER THIS LIMITED WARRANTY. AFC SHALL NOT BE LIABLE FOR ANY DAMAGES WHICH ARE BASED UPON NEGLIGENCE, BREACH OF WARRANTY, STRICT LIABILITY, OR ANY OTHER THEORY EXCEPT THE LIMITED WARRANTY SET FORTH ABOVE. INCIDENTAL AND CONSEQUENTIAL DAMAGES SHALL NOT BE RECOVERABLE EVEN IF THE REPLACEMENT REMEDY FAILS OF ITS PURPOSE OR FOR ANY OTHER REASON.





USA-BASED

Phone: **303.972.5107**

6901 South Pierce Street  
Suite 180, Littleton, CO 80128 USA

[americanfibercement.com](http://americanfibercement.com)